



PREDICTING FATIGUE IN LIFTING EQUIPMENT WITH SDC VERIFIER

EN 13001   15018

 F.E.M 1.001  EN 1993-1

 OS-C101/C201  1608, 1612



STRUCTURAL VERIFICATION SOFTWARE

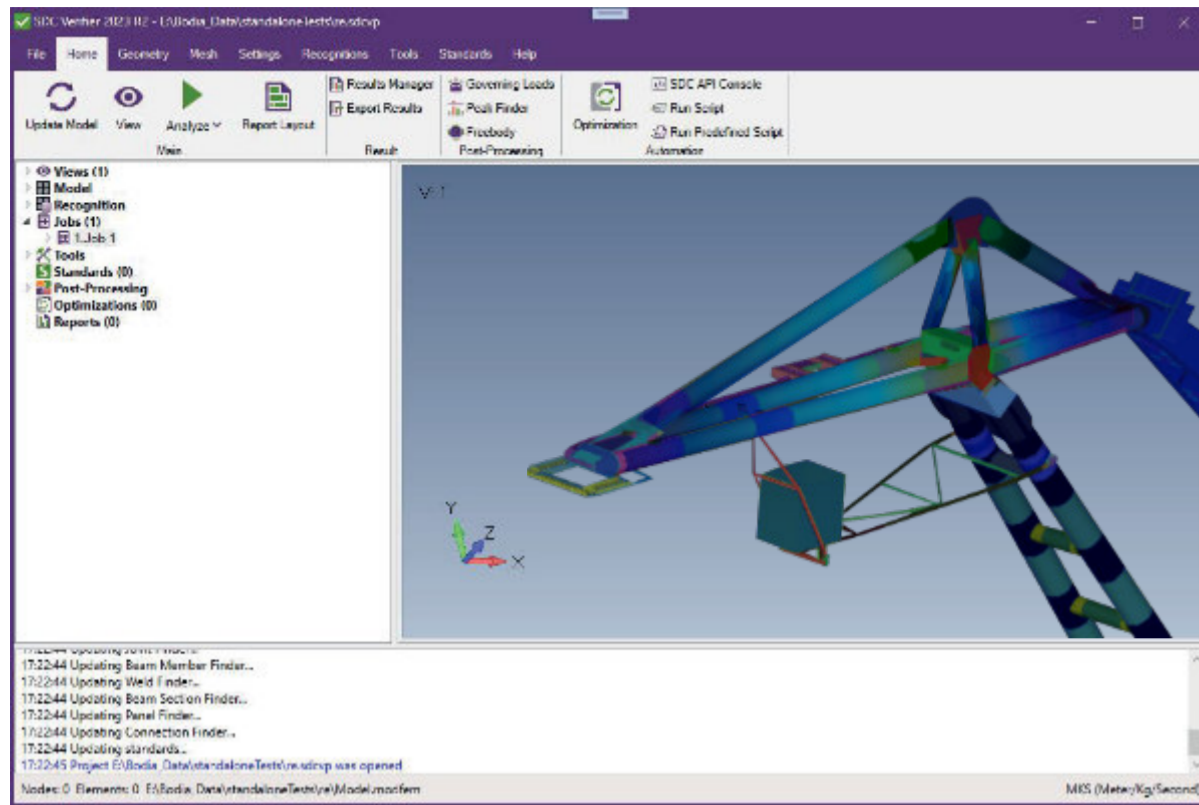

SDC Verifier is a software that verifies structures according to different design rules or codes. It works independently or on top of Ansys, Femap and Simcenter.

With SDC Verifier, the complete verification procedure can be saved and used as a template for other models.

Fatigue is a progressive structural damage of materials under the cyclic loading. SDC Verifier implements the following fatigue standards (based on the S-N curves):

EN 13001 (Cranes General Design, 2018), **F.E.M 1.001** (Rules for the Design of Hoisting Appliances), **DIN 15018** (Cranes. Steel structures. Verification and analyses), **FKM** (Analytical strength assessment (5th, 6th revised edition, 2003)), **Eurocode 3** (Design of steel structures), **DVS 1608** (Design and strength assessment of welded structures from aluminum alloys in railway applications), **DVS 1612** (Design and endurance strength analysis of steel welded joints in rail-vehicle construction).

The fatigue damage method is based on different loading patterns (*stress history*) and calculates fatigue life consumption for each cycle based on the stress variation and the number of load cycles.

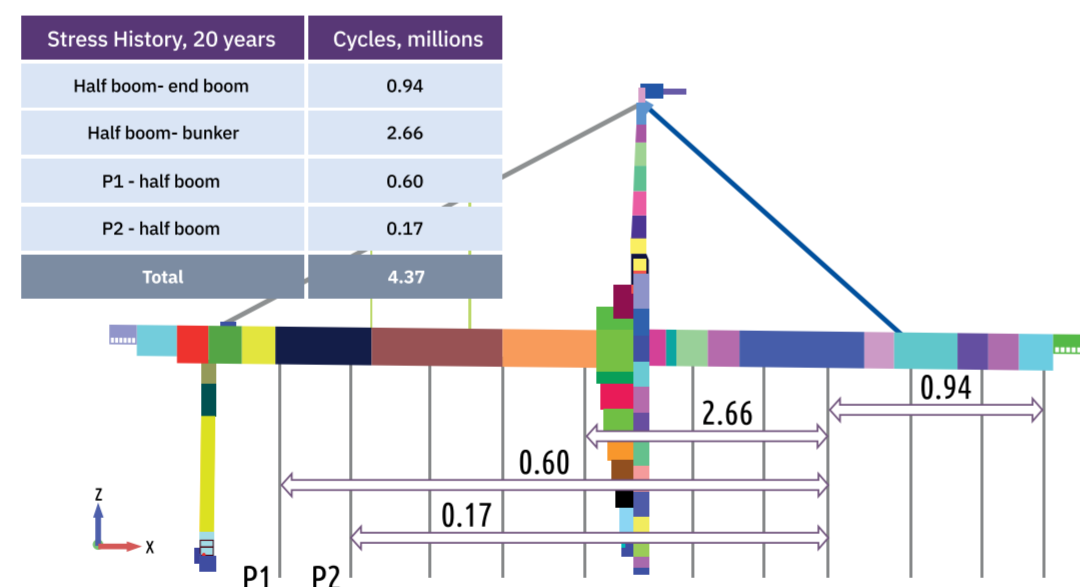

SDC Verifier tool **Weld Finder** detects welds and automatically transforms the stresses from the element's local coordinate system.

- non-welds ●
- welds ●
- crossing welds ●

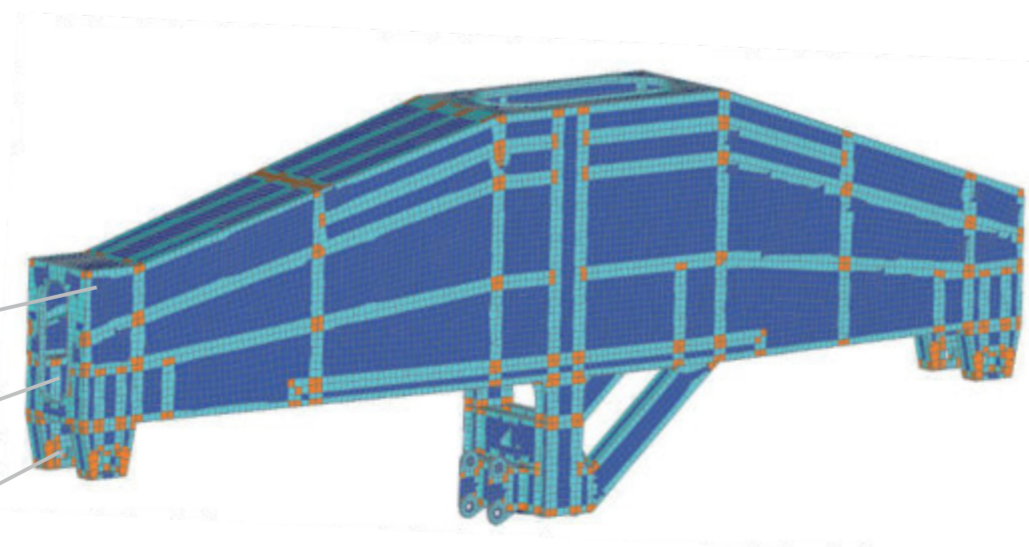

FATIGUE STANDARDS



EN 13001



DIN 15018



F.E.M 1.001



Eurocode 3



FKM (5th and 6th edition)



DNV 1995 & 2010



DVS 1608, DVS 1612

The notch group classification or fatigue strength of the welds depends on the quality and the stress direction along the weld (X), perpendicular to the weld (Y) and the shear (XY). Stresses are converted into weld direction automatically by the weld finder.

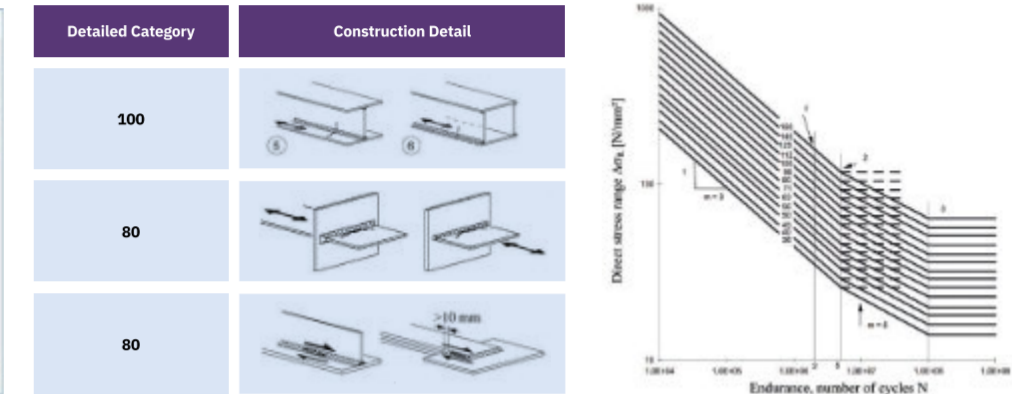
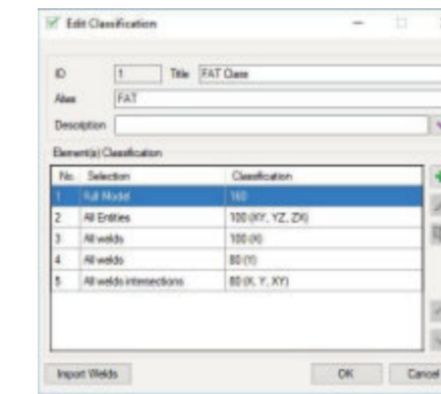

SDC Verifier performs a weld strength check according to **DNV-OS-C101/C201** (Fatigue Design of Offshore Steel Structures), **Eurocode 3** (Design of steel structures).

It is also possible to run Fatigue checks using **Hot Spot Stress Method**. Reference point settings are based on **IIW Fatigue Recommendations IIW-1823-07/ XIII-2151r4-07/XV-1254r4-07 Dec. 2008**:

The forces/moments of each element of the weld are summarized into the local weld coordinate system: The load on the total weld is compared to the capacity based on the length, and such parameters as throat thickness and angle

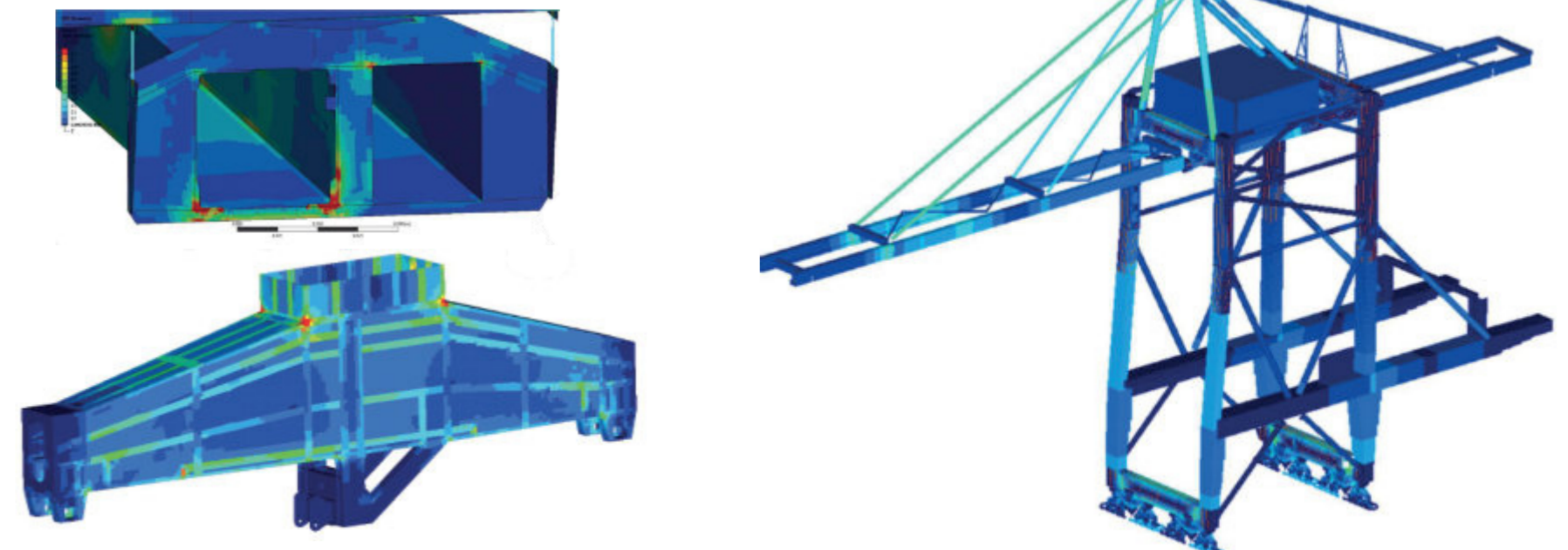
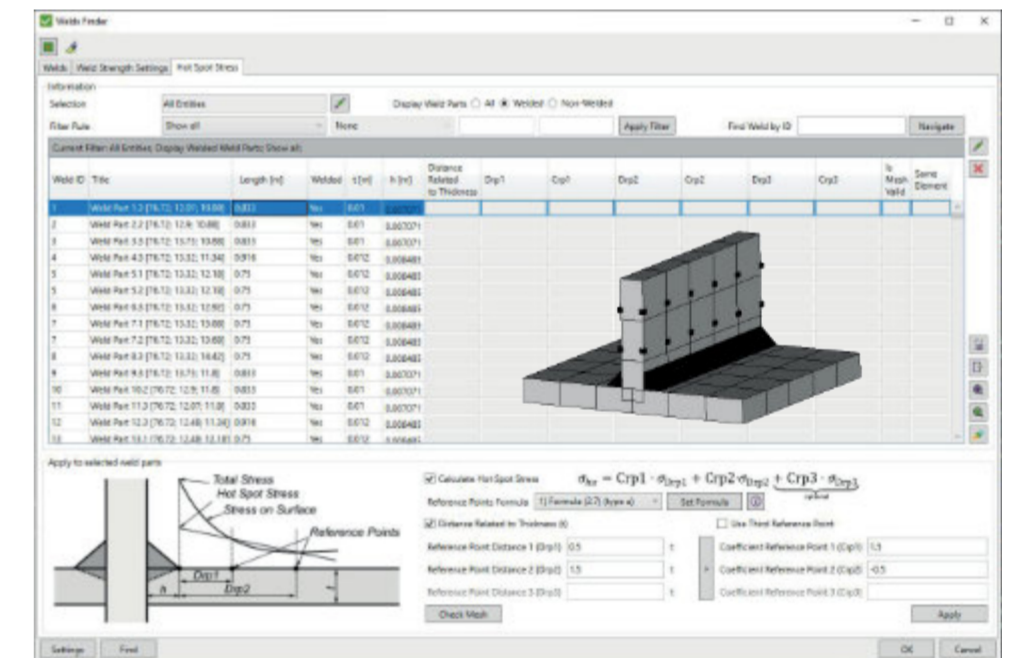
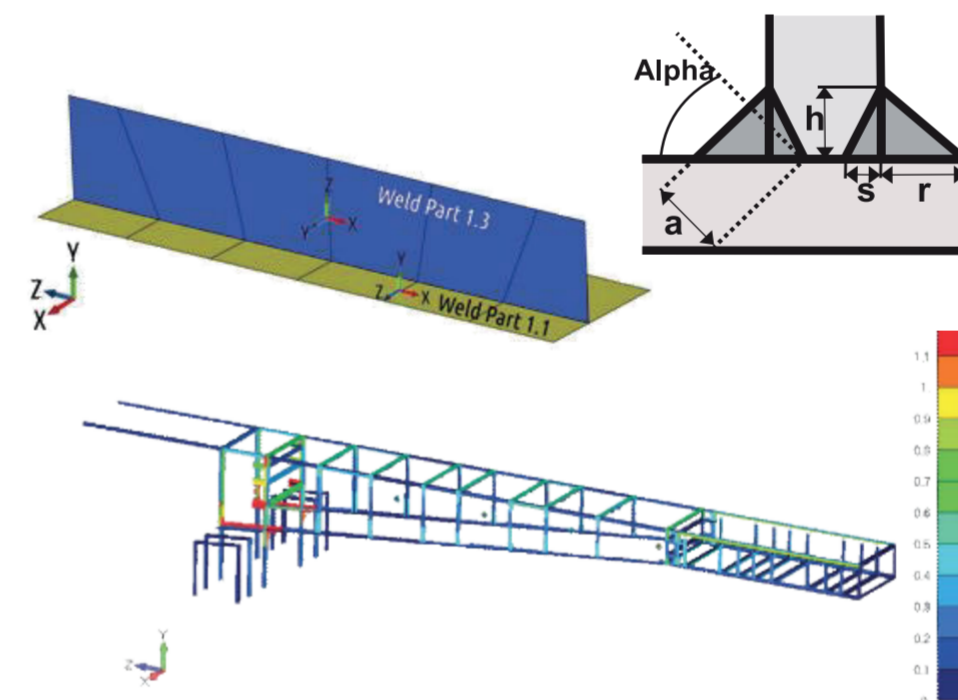

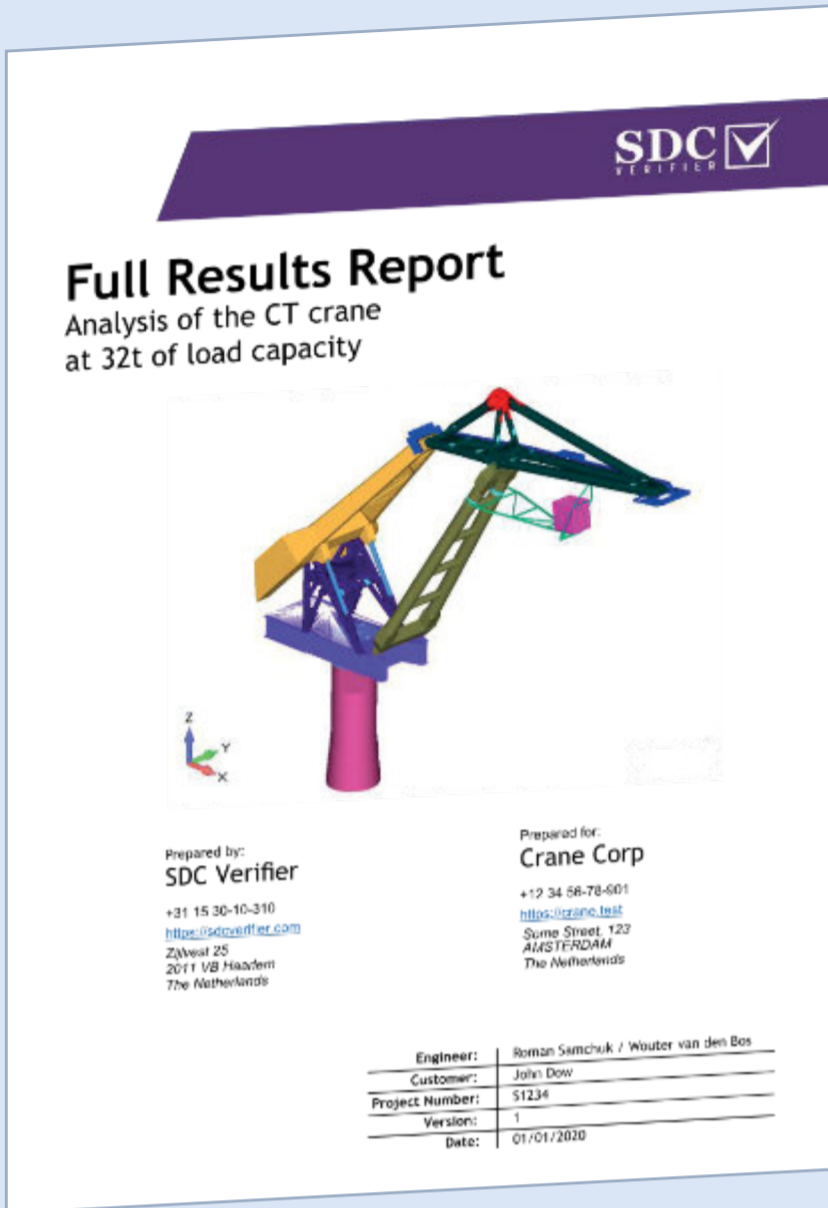

Report Designer is an advanced tool for automatic report generation. Reports in SDC Verifier have a template-based structure and contain model setup, model description, and calculated results presented as plots and tables. In case of any changes in the analysis process, all results could be regenerated with one click.

It is possible to preview and print the report in Report Designer or export to Microsoft Word, PowerPoint or Adobe PDF format for further editing.

Automatic report generation can save a lot of time for preparing and presenting the calculation results.

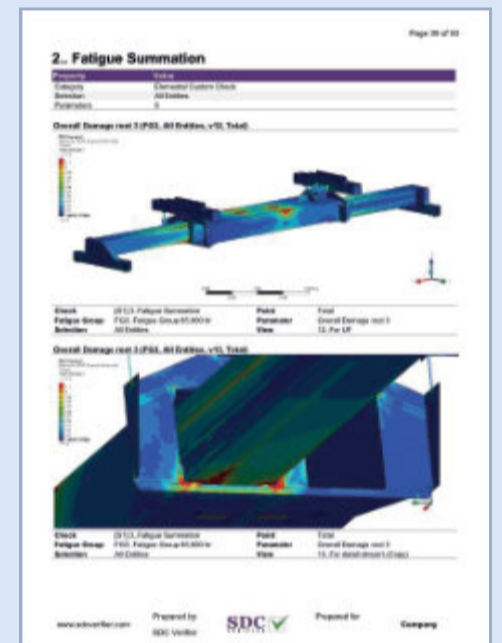
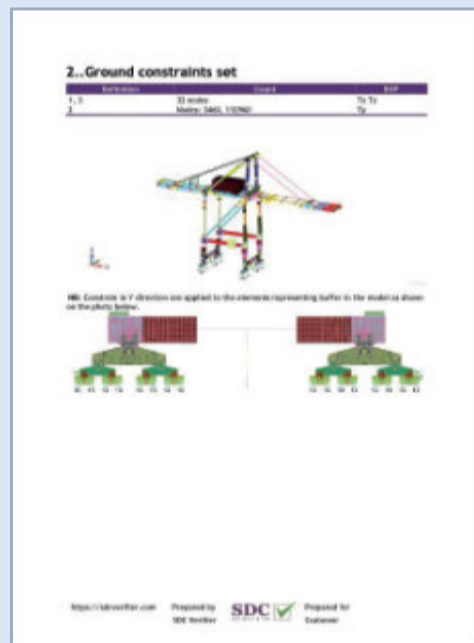

Netherlands,
Haarlem Zijlvest 25, 2011 VB

+31 23 369 90 36

sales@sdcverifier.com

sdcverifier.com

Member of:



GET



A TRIAL